

**Dr. Bhim Rao Ambedkar Engineering College
of Information Technology
Banda**

TENDER NOTICE No : BRAECIT-2/2015 -03

Tender Documents

FOR

**Supply and Installation of
Hostel and Laboratory Furniture**

AT

**Dr. Bhim Rao Ambedkar Engineering College
of Information Technology
Atarra, Banda -210201**

**Dr. Bhim Rao Ambedkar Engineering College
of Information Technology
Banda – 210201**

Tender	Supply and Installation of Hostel and Laboratory Furniture
Name of the firm with Full Address and Contact Numbers	
Cost of Tender Document	Rs. 2280/- (Non-Refundable with VAT)
Date of Commencement of Sale	01 May 2015 (Tender document may also be downloaded at www.bietjhs.ac.in)
Last date of Sale of Tender Documents	16 May 2015 (Saturday)
Last Date of Submission of Tender Documents	18 May 2015 upto 12.00 Noon (Monday)
Opening of Technical Bid: Date, Time and Place	18 May 2015 at 12.30 PM (Monday) Conference Hall, Administrative Block, Bundelkhand Institute of Engineering and Technology (BIET), Jhansi -284128. Bidder/Authorized Representative of Bidders may attend the bid opening proceedings on above mentioned date.
Opening of Financial Bid : Date, Time and Place	20 May 2015 at 12.30 PM (Wednesday) Conference Hall, Administrative Block, Bundelkhand Institute of Engineering and Technology (BIET), Jhansi -284128. Bidder/Authorized Representative of Bidders may attend the bid opening proceedings on above mentioned date.
Earnest Money Deposit (EMD)	As per Schedule/Package given in the tender document
Bid Shall Contain	<ol style="list-style-type: none"> 1. All documents in support of Terms & Conditions and Eligibility Criteria. 2. Bidders Proforma (Form-1 and Form-2) 3. Cost of Tender by way of Demand Draft only. 4. EMD by way of Demand Draft only.

Tender Issued By¹ :

Signature and Seal of Bidder

¹ The Tender Document may also be downloaded from web site <http://bietjhs.ac.in>

**Dr. Bhim Rao Ambedkar Engineering College
of Information Technology
Banda – 210201**

A. General Information to Bidders :

- [a] Dr. B R Ambedkar Engineering College of Information Technology, Banda was established in the year 2010 by Government of Uttar Pradesh. The college currently offers four year B.Tech program in three disciplines, namely, Mechanical Engineering, Electrical Engineering and Information Technology with intake of Sixty (60) each.
- [b] The classes of BRAECIT, Banda are presently being run at Bundelkhand Institute of Engineering and Technology, Jhansi campus. The construction work of the building of BRAECIT, Banda including Academic Blocks, Workshop, Hostels and Residences has been completed now. The college will be operational in its own campus from July 2015.
- [c] The new campus of BRAECIT, Banda is situated on Banda-Chitrakoot Road, approx 25 Km from Banda and 04 Km from town Atarra.
- [d] ***Tenders are being invited from reputed manufacturers /suppliers / distributors for supply and installation of Hotel Furniture (Student Steel Takhat/ Study Table and Study Chair) and furniture for laboratory (Laboratory Working table and Steel Stools) to establish various laboratories. Detail of Package (Furniture) along with cost of tender and earnest money is given in the tender document.***
- [e] Location/Halls for these laboratories have been identified within the main building. All rooms/halls are well finished with electric supply and tile floors.
- [f] ***In order to save the space, for Student Study Table and Study Chair to be used in the hostel rooms by the students, it is necessary that Table and Chair should be so designed that Chair can be slided beneath the table when chair is not in use.***

B. Eligibility Criteria

1. The firm should have satisfactorily completed the job of the same nature in different organizations of repute such as in Universities, Government Departments, and Public Sector Units or reputed State/Central Educational Institutions during last three years.

2. The bidder must have minimum turnover of Rs 50 Lacks per year for the last three consecutive years in the field of furniture manufacturing / distribution / dealership.
3. The firm must be registered with registrar of companies/ firms.
4. PAN/TIN number issued in the name of firm must be submitted.
5. Tender Fee to be submitted in the form of Demand Draft only in the favour of Director, Dr. B R Ambedkar Engineering College of Information Technology payable at Jhansi.
6. EMD is required to be submitted in the form of Demand Draft only in only in the favour of Director, Dr. B R Ambedkar Engineering College of Information Technology payable at Jhansi.
7. Authorized signatory should sign on all pages with rubber stamp. Bids without authorized signature/seal will be rejected.

C. Detail of Furniture Requirements (Package)

Package	Item Description	Quantity	Location	Earnest Money (in Rs)
Package-1	Student Takhat	800	Hostel	Rs 50000=00
Package-2	Student Study Table	800	Hostel	Rs 30000=00
	Student Study Chair	800		
Package-3	Lab Table (Large)	200	Laboratories	Rs 60000=00
	Lab Table (Small)	150		
	Lab Stool	800		

Specifications of these items are given in the tender document. Sketch of these items has also been given for better understanding of the specification.

C. Submission of the Bid:

1. Sealed tenders in two parts i.e., “**Technical Bid : FORM-1**” and “**Financial Bid : FORM-2**” are invited to **Supply and Installation of Hostel and Laboratory Furniture** at Dr Bhim Rao Ambedkar Engineering College of Information Technology, Atarra, Banda from reputed and registered service providers in the prescribed format.
2. Earnest money amounting to the value mentioned with each package in the tender document and cost of tender document **Rs 2280=00 (with VAT)** in the form of separate Demand Drafts drawn in favour of Director, Dr. B R Ambedkar Engineering College of Information Technology payable at Jhansi, should also submitted with the tender.
3. Envelopes containing “**Technical Bid : FORM-1**” and “**Financial Bid : FORM-2**” should be sealed in two separate envelopes.
4. First envelope must be superscripted by writing “**Tender for Supply and Installation of Hostel and Laboratory Furniture: Technical Bid- Form-1**”. This envelope contain Bidder Proforma “*Technical Bid : Form-1*” and necessary documents in support of terms and conditions, requirements and eligibility criteria. Technical Bid : Form-1 (Technical) shall contain (i) Tender cost (non refundable) (ii) Earnest Money (iii) Proof of PAN and TIN registration document (iv) Standing of the firm (v) Major supplies executed in recent past (vi) Authorized dealer certificate from OEM & Commercial terms and conditions.
5. Second envelope must be superscripted by writing “**Tender for Supply and Installation of Hostel and Laboratory Furniture: Financial Bid- Form-2**”. This envelope must contain Bidder proforma “**Financial Bid: FORM-2**”. **Financial Bid : Form-II** (Financial) shall contain rate schedule only. The rates must be quoted in both figures and words. Any overwriting and/or cutting must be duly attested failing which tenders are likely to be rejected.
6. Earnest money and Cost of tender in the form of Bank Drafts must be placed in a separate sealed envelope by writing “**Earnest Money**” on top of the envelope.
7. All the envelopes as above must be kept and sealed in a big envelop. The Package number/ name of package, enquiry/tender no and the opening date should invariably be mentioned on the top of big envelope. All forms and required draft should be placed in sealed envelope for each package separately in big envelope.
8. Sealed tenders should be sent by hand or registered post to Director, BRACEIT, Banda at Bndelkhand Institute of Engineering

and Technology (BIET) Campus, Kanpur Road, Jhansi -284128 so as to reach latest by **18 May 2015** at **12.00 Noon**. The sealed tenders may also be dropped in the box kept at Store and Purchase section at BIET, Jhansi campus.

D. Terms and Conditions for Inspecting, Testing & Quality Control of Furniture/Goods and Guarantee/Warrantee

1. All the goods ordered shall be delivered within 4 (Four) week from the date of issue of Supply order. All the aspects of safe delivery shall be the exclusive responsibility of the supplier.
2. BRAECIT, Banda may inspect and test the ordered goods and the related services to confirm their conformity to the contract specification and other quality control details incorporated.
3. The BRAECIT, Banda reserves the right for inspection at different stage during manufacturing process, pre-dispatch inspection or post-delivery inspection. The BRAECIT, Banda as deemed fit may resort to all these inspection if felt necessary.
4. Before resorting to Bulk Manufacture, the supplier/firm shall offer/send the prototype/ actual finished sample for approval by the Inspecting Committee authorized by the BRAECIT, Banda. This has to be intimated to BRAECIT, Banda in writing before bulk manufacture. The approval of Samples shall be in respect of workmanship and finishing and shall be without prejudice to the rights of purchaser/user to get random testing of items during pre-dispatch inspection or from the actual lot offered.
5. If the sample presented by the Firm is not approved by BRAECIT, Banda, the firm has to prepare another sample for approval. If the sample is again not approved by BRAECIT, Banda, the BRAECIT, Banda may take appropriate step leading to the cancellation of work order.
6. In the event of the failure of the supplier to deliver the sample by the date specified in the contract or any other date agreed to by the purchaser or in the event of rejection of the sample for the second time, the purchaser shall be entitled to cancel the contract and purchase.
7. In the event of rejection of the sample for the second time, the purchaser shall be entitled to cancel the contract and purchase the stores at the risk and cost of the supplier.
8. The Inspecting committee authorized by BRAECIT, Banda shall have full and free access at any time during the execution of the contract to the supplier's work for satisfying himself that the goods are being manufactured in accordance with the specification mentioned in the Contract. The decision of the purchaser/ inspection authority in this

regard shall be final and binding on the Supplier. All terms and condition of the contract as they apply to the inspection shall also apply to the re-inspection.

9. The BRAECIT, Banda reserves the right to draw samples through random sampling method after receiving the finished goods at destination.
10. The on-site replacement warranty shall remain for a period of 12 Months from the date of recording of acceptance of goods at site.
11. During warranty period, the supplier is required to visit BRAECIT, Banda site at least once in 6 months commencing from the date of delivery of the goods for preventive maintenance of the goods.
12. If the supplier having been notified, fails to respond to take action to replace the defect(s) within 10 days the purchaser may proceed to take remedial action(s) as deemed fit.

E. Other Terms and Conditions for Submission of Tenders

1. Sealed quotations/tenders should be sent to Director, BRACEIT, Bndelkhand Institute of Engineering and Technology (BIET) Campus, Kanpur Road, Jhansi -284128.
2. Our enquiry/tender no and the opening date should be mentioned on the top of envelope alongwith name of user department. Earnest money and cost of tender must be placed in a separate sealed envelope by writing "Earnest Money" on top of the envelope.
3. Firms will have to attach the list of customers to whom they have supplied similar items in previous year along with performance reports. Total turnover of the firm must be atleast 50 Lacs per year in the last three consecutive years. A certificate to these effects should be issued from the sales tax department.
4. The descriptive and illustrative literature of the quoted item in original must accompany with the tender.
5. Tenders received after the closing date and stipulated time shall not be considered and the institute shall not be responsible for any postal delay.
6. Tender should be valid atleast for a periode of 04 months. (04 Months from opening date of tender).
7. The rates must be quoted in both figures and words. Any overwriting and/or cutting must be duly attested, failing with quotations/tenders are likely to be rejected.
8. Our terms of payments are strictly after receipt of material and check at our institute regarding the quality and working experience.

9. The rates should be quoted for store, Dr Bhim Rao Ambedkar Engineering College of Information Technology, Atarra, Banda-210201 inclusive of all taxes /excise duty /fright /package /forwarding expenses /insurance etc.
10. Firm shall be solely responsible for defective supplies and losses caused to college on account of defective supply.
11. Quotation/ Tender brought personally should be dropped into into tender box.
12. Suppliers must be registered with sales tax department and they should state registration no.
13. Quantity of items may increase or decrease or may be cancelled upto any extent.
14. No sales tax form "C" or "D" etc for concessional rate shall be provided by the institute.
15. All tender must be accompanied by EMD as mentioned in the tender document in the form of demand draft / Bankers Cheque drawn in favour of Director, Dr B R Ambedkar Engineering College of Information Technology payable at Jhansi.
16. Quotations deviating from above terms and conditions shall be rejected straight way without assigning any reason thereof.
17. Security bid will be forfeited if the equipment's are not supplied in given time.
18. If required, the firms have to supply the sample of the items.
19. If certain equipment/material needs to be checked/tested at site of the firm, all expenditure (including TA/DA) of our expert members shall be borned by the firm concerned.
20. Penalty : The firm, which is not able to supply the equipment's/materials mentioned in purchase order by the due date , shal be liable to pay a penalty equal to 0.10 % of the value of purchase order per day. However this can be waived of by the Director under special circumstances.
21. Ninety percent of contract price shall be paid to the supplier within 30 days after the delivery / commissioning / testing and completion of the work. The remaining 10% of contract price shall be paid to the supplier within 30 days after the date of acceptance certificate issued by purchaser representative for the satisfactory working.
22. Director has every right to extend the due date if so required but all the quotations/tenders will be opened together.
23. Deduction of TDS as per Govt Rules.
24. The College may reject any or all quotations/tenders without assigning any reasons.
25. The firm must provide original Guarantee/Warrantee card as issued by the manufacturer, as the case may be.
26. All tender must be accompanied by EMD and Cost of Tender as mentioned in the tender document in the form of demand draft / Bankers Cheque drawn in favour of Director, Dr B R Ambedkar Engineering College of Information Technology payable at Jhansi.

27. Quotations deviating from the terms and conditions shall be rejected straight way without assigning any reason thereof.
28. Director, BRAECIT, Banda has every right to extend the due date, if so required, but all the quotations/tenders will be opened together.
29. The BRAECIT, Banda may reject any or all quotations/tenders without assigning any reasons.

For BRAECIT, Banda

**Dr. Bhim Rao Ambedkar Engineering College
of Information Technology
Banda – 210201**

TECHNICAL BID: FORM-1 for Package-1

Tender	Supply and Installation of Hostel and Laboratory Furniture Student Takhat
Name of the firm with Full Address and Contact Numbers	
FOR	Dr B R Ambedkar Engineering College of Information Technology, Banda. (Located on Banda-Chitrakoot Road, approx 20 Km from Banda and 04 Km from town Atarra)
Cost of Tender Document	DD No : Amount : Bank : Date : (DD must be drawn in favour of Director, Dr. B R Ambedkar Engineering College of Information Technology payable at Jhansi).
Earnest Money Deposit (EMD)	DD No : Amount : Bank : Date : (DD must be drawn in favour of Director, Dr. B R Ambedkar Engineering College of Information Technology payable at Jhansi).
PAN/TIN/TAN No	Attach Proof
Proof of the last three year's turnover of the firm (It must not be less than Rs. 50 Lakhs (Rupees Fifty Lakh only) each in the last three consecutive financial years.	Attach Proof
Details of Similar Work Executed during last THREE years	Attach Proof

FINANCIAL BID : FORM-II for Package-1

Package No	Item Description	Unit Price (In Rs)	VAT /All Taxes (In Rs)	Total Unit Price with all taxes (In Rs)
Package-1	Student Takhat			

**Dr. Bhim Rao Ambedkar Engineering College
of Information Technology
Banda – 210201**

TECHNICAL BID: FORM-1 for Package-2

Tender	Supply and Installation of Hostel and Laboratory Furniture Student Study Table and Study Chair
Name of the firm with Full Address and Contact Numbers	
FOR	Dr B R Ambedkar Engineering College of Information Technology, Banda. (Located on Banda-Chitrakoot Road, approx 20 Km from Banda and 04 Km from town Atarra)
Cost of Tender Document	DD No : _____ Amount : _____ Bank : _____ Date : _____ (DD must be drawn in favour of Director, Dr. B R Ambedkar Engineering College of Information Technology payable at Jhansi).
Earnest Money Deposit (EMD)	DD No : _____ Amount : _____ Bank : _____ Date : _____ (DD must be drawn in favour of Director, Dr. B R Ambedkar Engineering College of Information Technology payable at Jhansi).
PAN/TIN/TAN No	Attach Proof
Proof of the last three year's turnover of the firm (It must not be less than Rs. 50 Lakhs (Rupees Fifty Lakh only) each in the last three consecutive financial years.	Attach Proof
Details of Similar Work Executed during last THREE years	Attach Proof

FINANCIAL BID: FORM-II for Package-2

Package No	Item Description	Unit Price (In Rs)	VAT /All Taxes (In Rs)	Total Unit Price with all taxes (In Rs)
Package-2	Student Study Table			
	Student Study Chair			

**Dr. Bhim Rao Ambedkar Engineering College
of Information Technology
Banda – 210201**

TECHNICAL BID: FORM-1 for Package-3

Tender	Supply and Installation of Hostel and Laboratory Furniture Laboratory Table (Large), Laboratory Table (Small), Lab Stool
Name of the firm with Full Address and Contact Numbers	
FOR	Dr B R Ambedkar Engineering College of Information Technology, Banda. (Located on Banda-Chitrakoot Road, approx 20 Km from Banda and 04 Km from town Atarra)
Cost of Tender Document	DD No : _____ Amount : _____ Bank : _____ Date : _____ (DD must be drawn in favour of Director, Dr. B R Ambedkar Engineering College of Information Technology payable at Jhansi).
Earnest Money Deposit (EMD)	DD No : _____ Amount : _____ Bank : _____ Date : _____ (DD must be drawn in favour of Director, Dr. B R Ambedkar Engineering College of Information Technology payable at Jhansi).
PAN/TIN/TAN No	Attach Proof
Proof of the last three year's turnover of the firm (It must not be less than Rs. 50 Lakhs (Rupees Fifty Lakh only) each in the last three consecutive financial years.	Attach Proof
Details of Similar Work Executed during last THREE years	Attach Proof

FINANCIAL BID: FORM-2 for Package-3

Package No	Item Description	Unit Price (In Rs)	VAT /All Taxes (In Rs)	Total Unit Price with all taxes (In Rs)
Package-3	Lab Table (Large)			
	Lab Table (Small)			
	Lab Stool			

Specifications

1. **Student Steel Takhat :**

Takhat Size 6ft X 3 ft X 1.5 ft , Made out of 35x35x5 mm ANGLE IRON, 2 Center Support 35x5 mm, welding should be grinded, Frame Duly Painted Black Color, 19 mm Plyboard ISI Mark fitted with 14 No Nut and Bolt inside the angle iron frame.

2. **Student Study Table :**

Size 2ft x 2 ft top, 2 ft 6 In Height, Made out of 25X25 MM 18 SWG Square Pipe and tie with all legs, Welding should be grinded, Frame Duly painted, 18 mm PLPB Top, Rubber footings.

3. **Student Study Chair :**

Made out of 19 mm round pipe 18 SWG (Legs) and ring support tie with legs (12 mm round pipe 18 SWG), 1ft 6In Dia, Welding should be grinded, Frame Duly painted, 16 SWG MS perforated seat.

4. **Lab Table (Large) :**

Size 6ft x 4 ft x 3ft, Made out of 40 mm Square Pipe, 16 SWG, Ties with Leg and Centre support, Welding should be grinded, Frame Duly Painted, 18 mm PLPB Top with Electrical Modular Switch + Socket 6 set 5A and 15 A combined mounted on the top of table with PVC Box, ISO certified.

5. **Lab Table (Small) :**

Size 4ft x 4 ft x 3ft, Made out of 40 mm Square Pipe 16 SWG, Ties with Leg and Centre support, Welding should be grinded, Frame Duly Painted, 18 mm PLPB Top with Electrical Modular Switch + Socket 4 set 5A and 15A combined mounted on the top of table with PVC Box, ISO certified.

6. **Lab Stool :**

1ft 6 In X 1ft 6 In, 2” Height, 18 mm PLPB Top, Made out of 25 mm Square pipe 18 SWG with Leg Support (H Shape), Welding should be grinded, Frame Duly Painted.

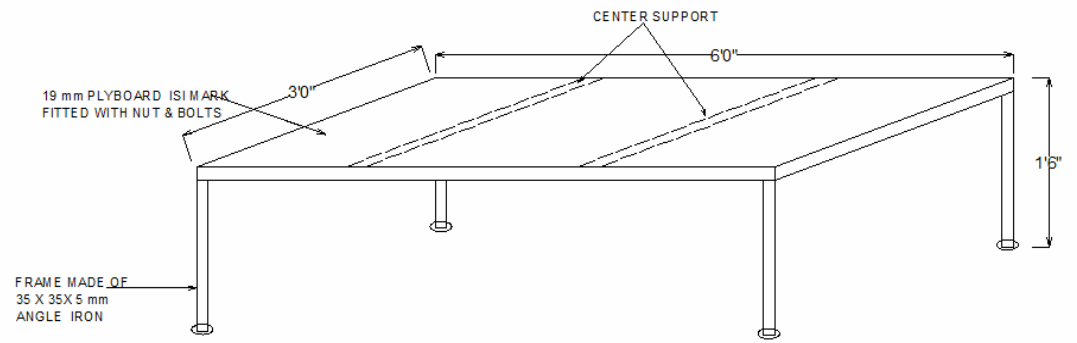

STUDENT STEEL TAKHAT (6'X3')

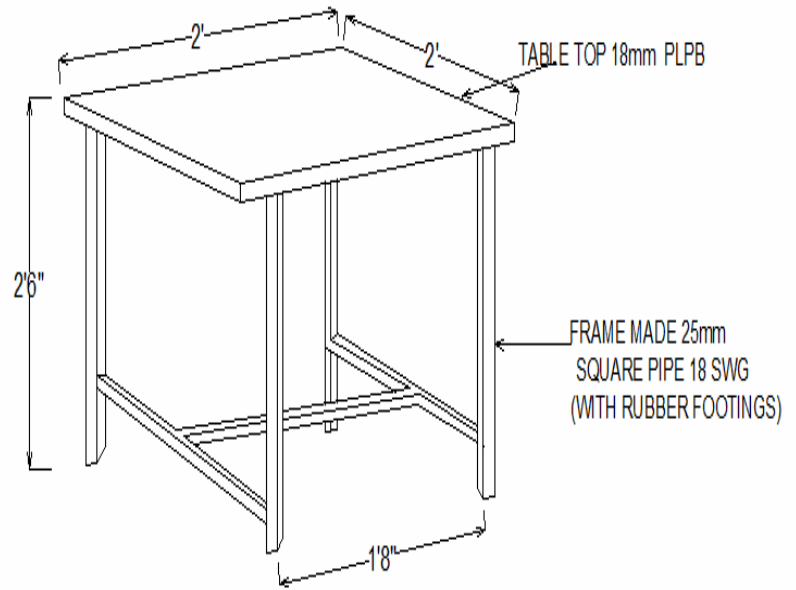

STUDY TABLE

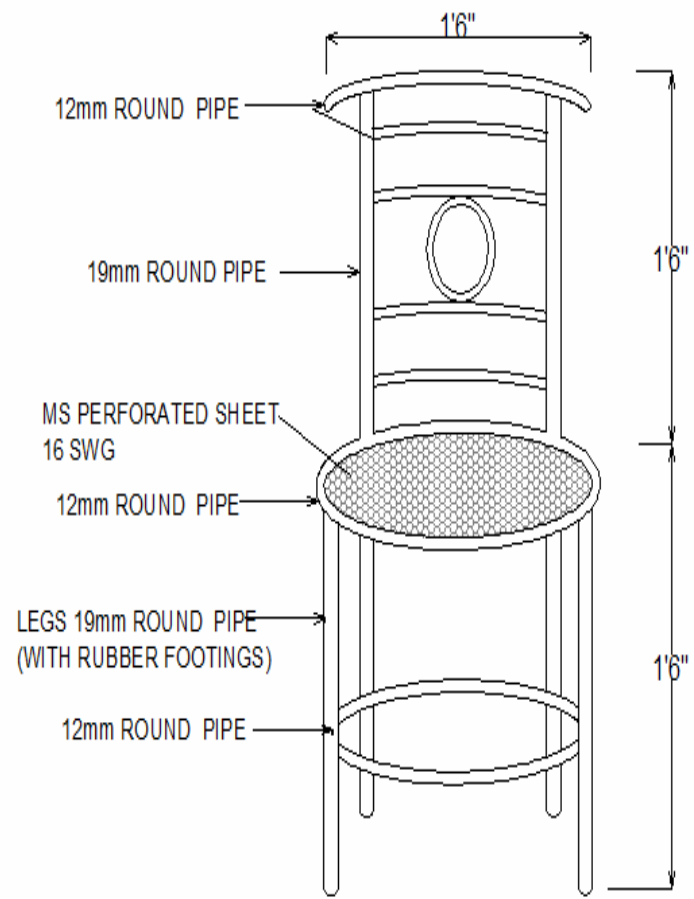

STUDY CHAIR

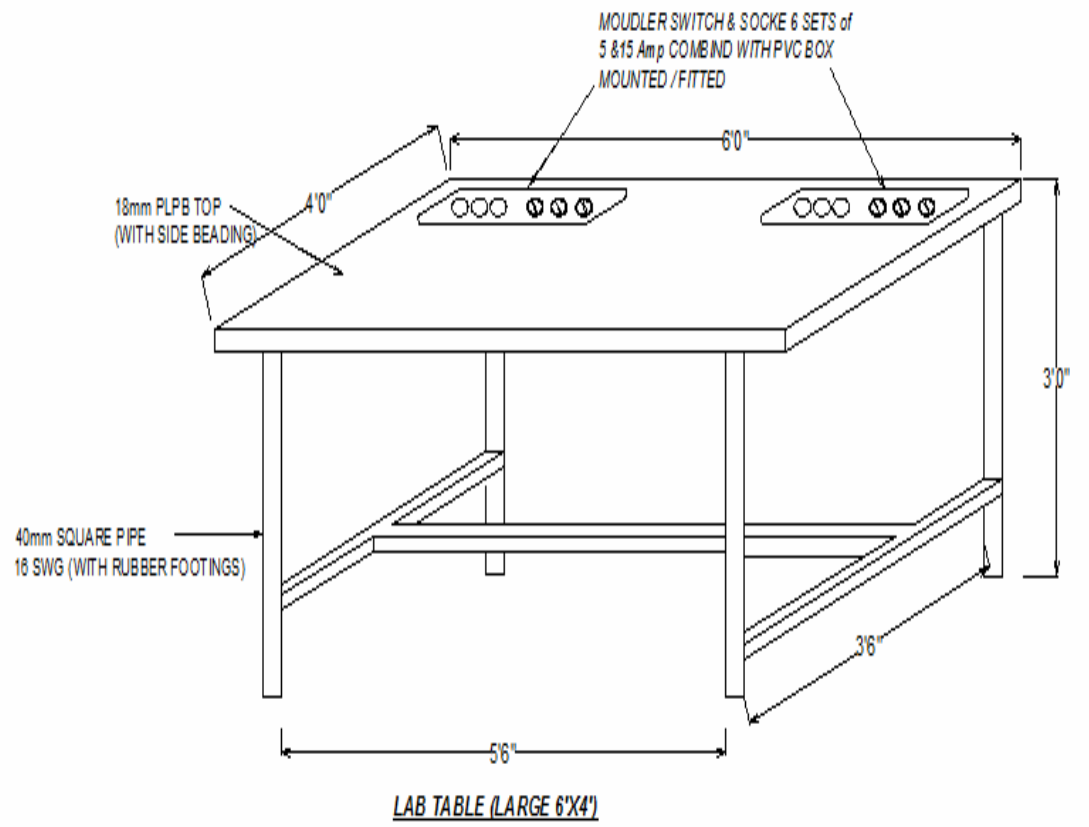

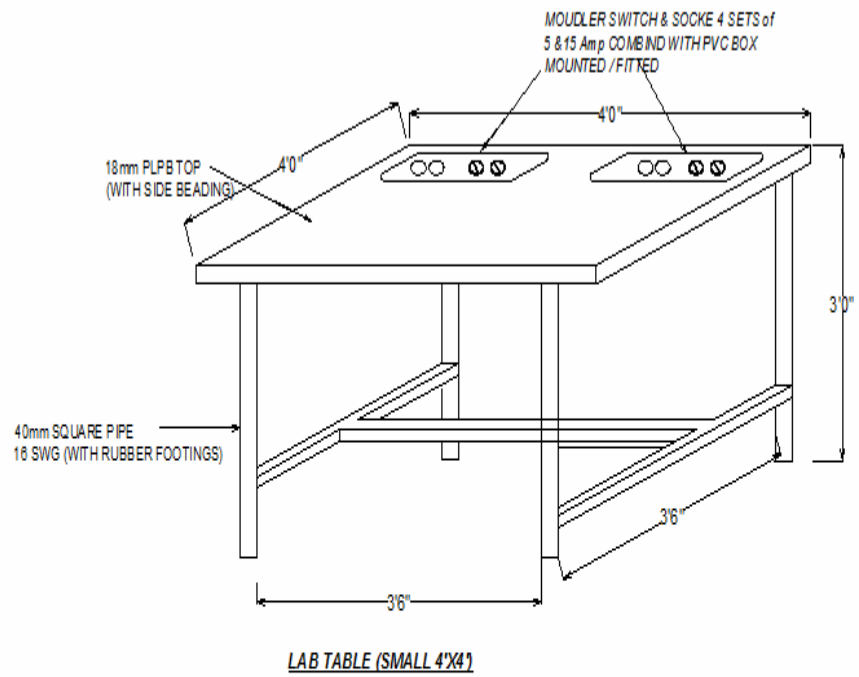

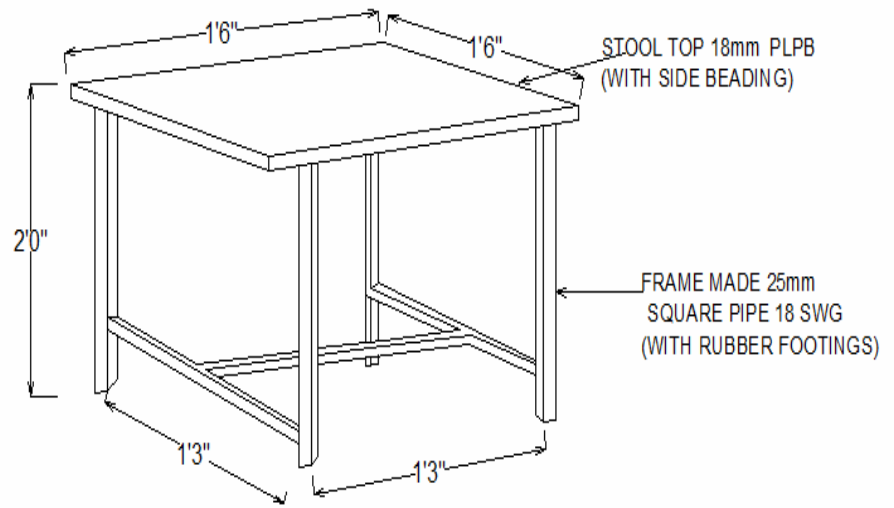

LAB STOOL